

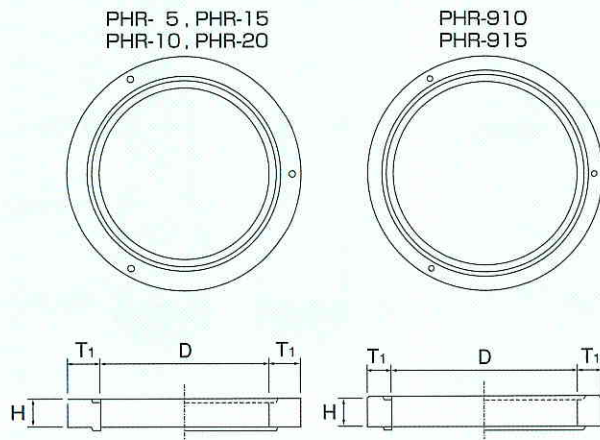

パワーホールの部材規格

調整リング (PHR)



スラブ (PHY)

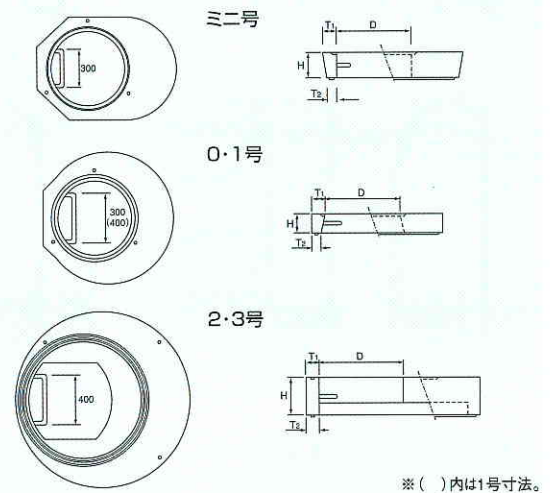

斜壁 (PHR)

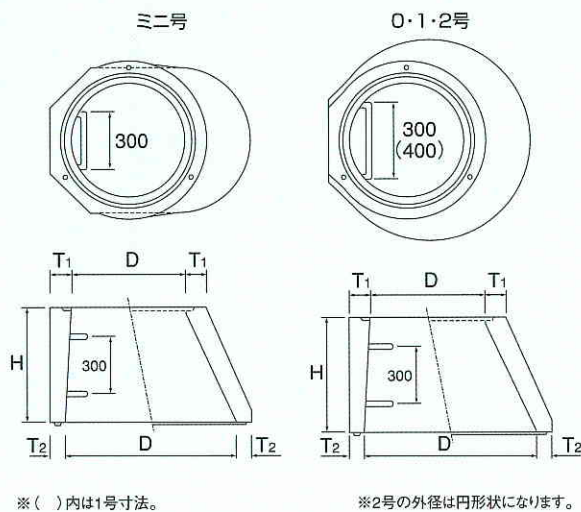

管取付壁 (PHC-K)

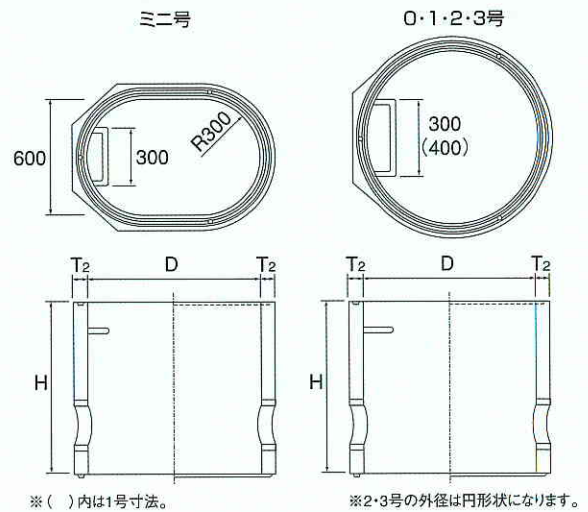

直壁 (PHC)

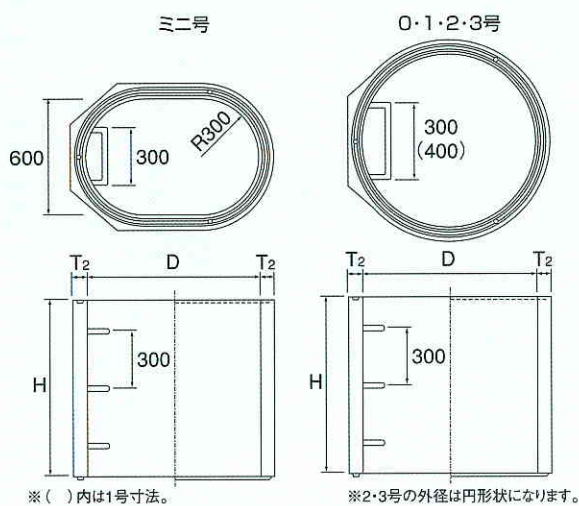

底版 (PHB)

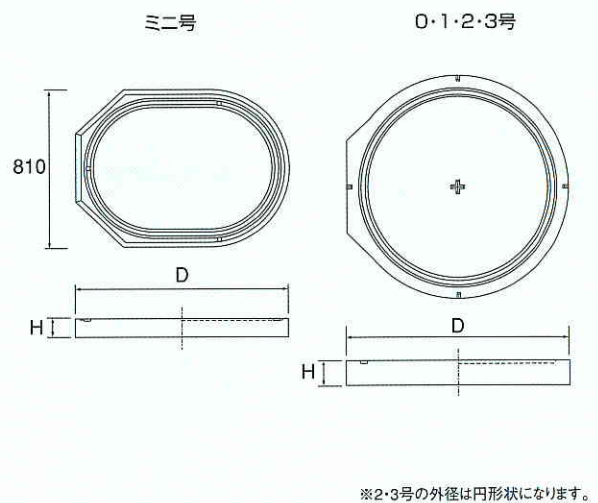

種類	呼び名	内径		有効高 H	参考重量 (kg)	種類	呼び名	厚さ		有効高 H	参考重量 (kg)					
		D	T1 T2					T1 T2								
調整リング	PHR- 5	600	110	—	50	29	スラブ	ミニ号	PHY-M-20	600	110	80	200	192		
	PHR- 10	600	110	—	100	58		0号	PHY- 0-15	600	110	70	150	118		
	PHR- 15	600	110	—	150	88		1号	PHY- 1-15	600	110	75	150	214		
	PHR- 20	600	110	—	200	117		2号	PHY- 2-30	900	120	100	300	666		
	PHR-910	900	120	—	100	93		3号	PHY- 3-30	900	120	150	300	1238		
	PHR-915	900	120	—	150	140										
斜壁	ミニ号	PHS-M-30	600/900	110	80	300	196	ミニ号	PHC-M- 60K	900	—	80	600	335		
		PHS-M-45	600/900	110	80	450	275		PHC-M- 90K	900	—	80	900	502		
		PHS-M-60	600/900	110	80	600	347		PHC-M-120K	900	—	80	1200	670		
									PHC-M-150K	900	—	80	1500	837		
	0号	PHS-O-30	600/750	110	70	300	171	0号	PHC-M-180K	900	—	80	1800	1004		
		PHS-O-45	600/750	110	70	450	250		PHC-O- 60K	750	—	70	600	271		
		PHS-O-60	600/750	110	70	600	330		PHC-O- 90K	750	—	70	900	407		
	1号	PHS-1-30	600/900	110	75	300	210	0号	PHC-O-120K	750	—	70	1200	541		
		PHS-1-45	600/900	110	75	450	302		PHC-O-150K	750	—	70	1500	673		
		PHS-1-60	600/900	110	75	600	390		PHC-O-180K	750	—	70	1800	812		
	2号	PHS- 2-30	600/1200	110	100	300	437	管取 付壁	1号	PHC-1- 60K	900	—	175	600	347	
		PHS- 2-45	600/1200	110	100	450	556			PHC-1- 90K	900	—	175	900	520	
		PHS- 2-60	600/1200	110	100	600	675			PHC-1-120K	900	—	175	1200	694	
		PHS-C2-30	900/1200	120	100	300	394			PHC-1-150K	900	—	175	1500	867	
		PHS-C2-45	900/1200	120	100	450	538			PHC-1-180K	900	—	175	1800	1040	
		PHS-C2-60	900/1200	120	100	600	679									
	直壁	ミニ号	PHC-M- 30	900	—	80	300	167	2号	PHC-2- 60K	1200	—	100	600	588	
			PHC-M- 60	900	—	80	600	335		PHC-2- 90K	1200	—	100	900	882	
PHC-M- 90			900	—	80	900	502	PHC-2-120K		1200	—	100	1200	1176		
PHC-M-120			900	—	80	1200	670	PHC-2-150K		1200	—	100	1500	1470		
PHC-M-150			900	—	80	1500	837	PHC-2-180K		1200	—	100	1800	1764		
PHC-M-180			900	—	80	1800	1004									
0号		PHC-O- 30	750	—	70	300	135	3号	PHC-3- 60K	1500	—	150	600	1072		
		PHC-O- 60	750	—	70	600	271		PHC-3- 90K	1500	—	150	900	1609		
		PHC-O- 90	750	—	70	900	407		PHC-3-120K	1500	—	150	1200	2145		
		PHC-O-120	750	—	70	1200	541		PHC-3-150K	1500	—	150	1500	2682		
		PHC-O-150	750	—	70	1500	673		PHC-3-180K	1500	—	150	1800	3218		
		PHC-O-180	750	—	70	1800	812									
1号		PHC-1- 30	900	—	75	300	174	底版	ミニ号	PHB-M- 10	1110	—	—	100	185	
		PHC-1- 60	900	—	75	600	347		0号	PHB- 0 - 13	990	—	—	130	231	
		PHC-1- 90	900	—	75	900	520		1号	PHB- 1 - 13	1150	—	—	130	314	
		PHC-1-120	900	—	75	1200	694		2号	PHB- 2 - 15	1500	—	—	150	615	
		PHC-1-150	900	—	75	1500	867		3号	PHB- 3 - 20	1900	—	—	200	1305	
		PHC-1-180	900	—	75	1800	1040									
		2号	PHC-2- 30	1200	—	100	300		294							
			PHC-2- 60	1200	—	100	600		588							
			PHC-2- 90	1200	—	100	900		882							
			PHC-2-120	1200	—	100	1200		1176							
			PHC-2-150	1200	—	100	1500		1470							
			PHC-2-180	1200	—	100	1800		1764							
3号	PHC-3- 30	1500	—	150	300	536										
	PHC-3- 60	1500	—	150	600	1072										
	PHC-3- 90	1500	—	150	900	1609										
	PHC-3-120	1500	—	150	1200	2145										
	PHC-3-150	1500	—	150	1500	2682										
	PHC-3-180	1500	—	150	1800	3218										

※1号、2号、の斜壁、直壁、管取付壁、底版には深形タイプ(H=100)があります。
 ※踊り場には、1号(φ900)、2号(φ1200)、3号(φ1500)があります。
 ※底版のみD寸法は外形寸法となります。
 ※2、3号の外径は丸型形状になります。